

Serie Compact per Termoformatura in linea

Compact Series for in-line Thermoforming

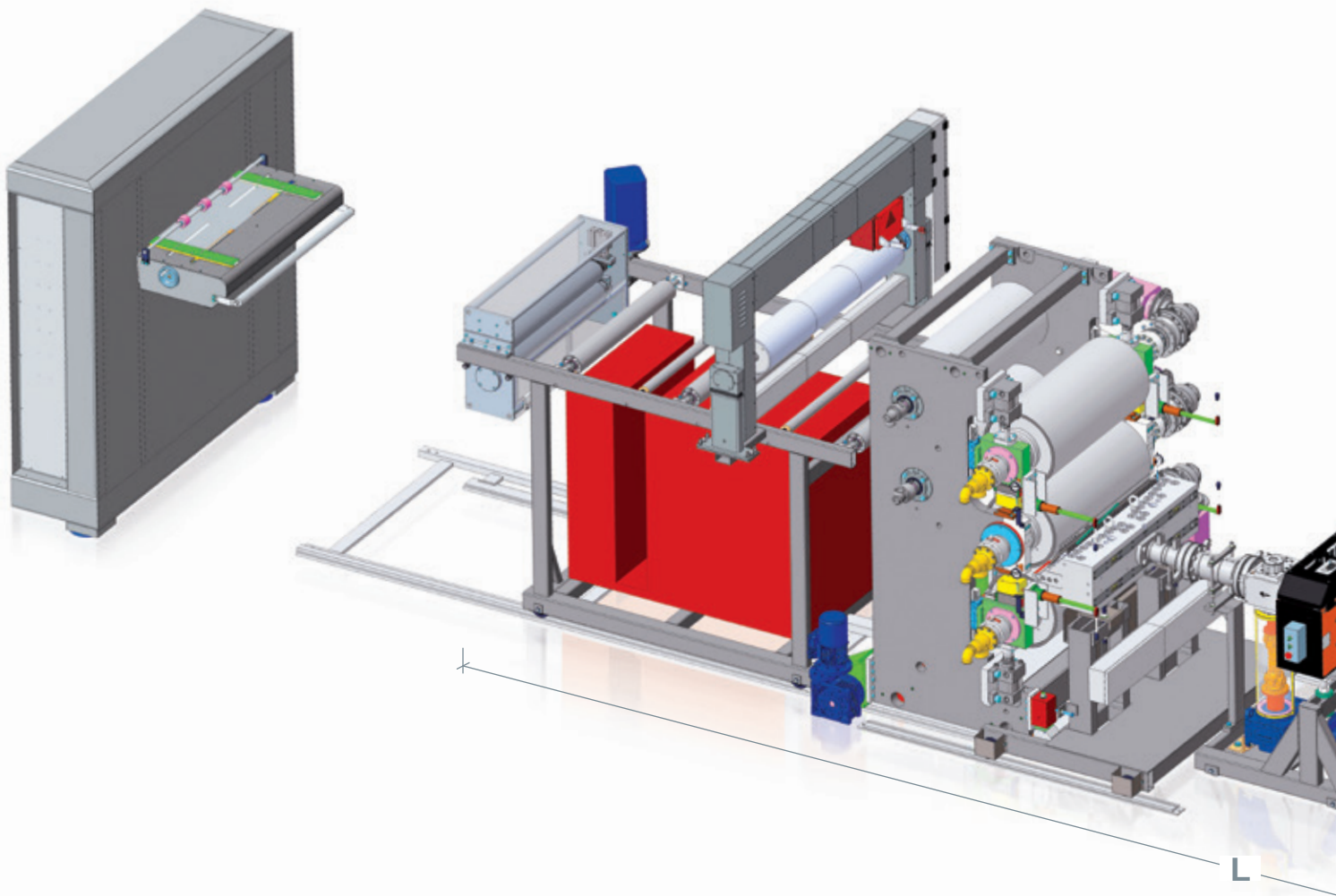



Configurazione: foglia monostrato o multistrato
Larghezza nominale: fino a 1300 mm
Spessore: HIPS 0,12 ÷ 2,5 mm
 PP 0,25 ÷ 2,5 mm
Materiali: PP, HIPS (fino al 100% degli scarti riciclati dallo scheletro di termoformatura)

Adatta per termoformatrici AMUT-COMI o di altre marche commerciali.
 Esecuzione compatta con una soluzione completa che copre calandra e traino.
 Agevoli operazioni di funzionamento e bassi costi di manutenzione.

Optional:

- Regolazione motorizzata del gap.
- Cilindri di raffreddamento supplementari (a seconda dello spessore e della produttività).
- Misuratore di spessore.
- Barre antistatiche.

Principali caratteristiche tecniche

Modelli	KVA-ITF90	KVB-ITF110	KVB-ITF130
Larghezza foglia (fino a) mm	700	900	1100
Portata (fino a) kg/h	700	1000	1200
Estrusore* modello	EA75	EA100	EA130
Cilindro (Ø) mm	400	450	500
Lunghezza (L) mm	8200	10300	11800

* Equipaggiato con Easy Feed® 40D o 52D.

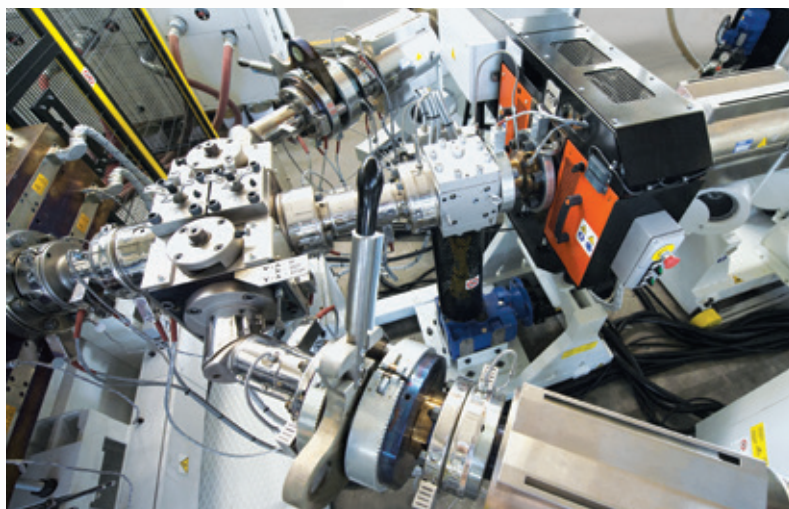

Esempio di configurazione a 5 strati
Example of 5-layer configuration

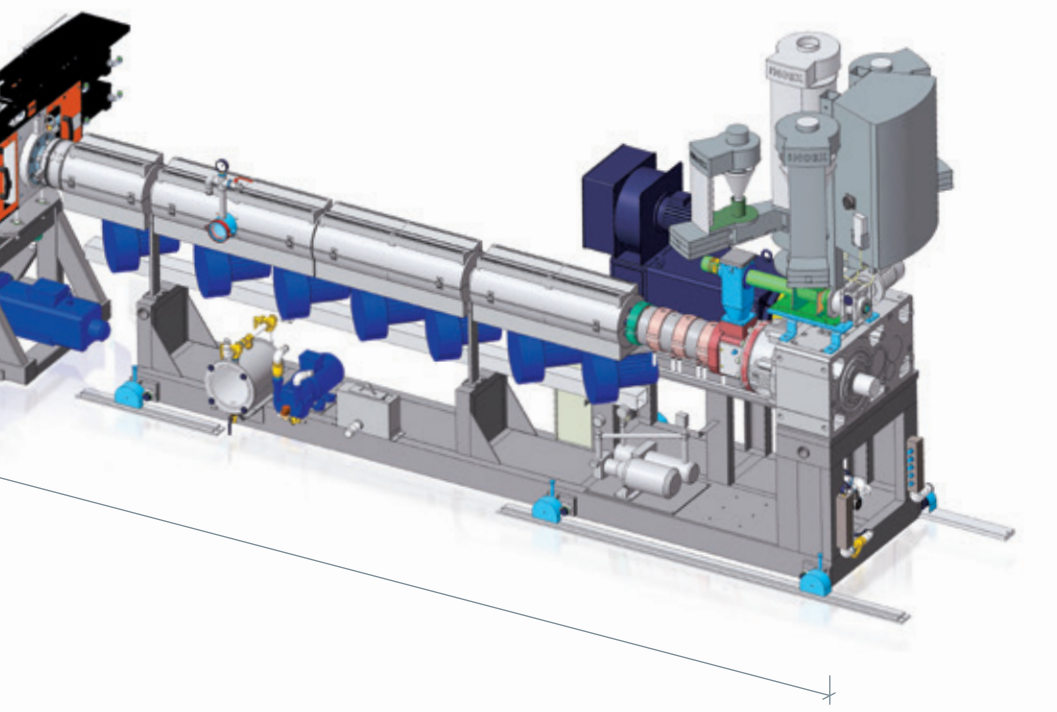

Configuration: monolayer or multilayer sheet
Nominal width: up to 1300 mm
Thickness: HIPS 0,12 ÷ 2,5 mm
 PP 0,25 ÷ 2,5 mm
Materials: PP, HIPS (up to 100% of recycled scraps from thermoformed skeleton).

Suitable to fit AMUT-COMI or main commercial brand thermoforming machines.
 Compact execution with roll-stack in a package solution including haul-off.
 Easy operation and low maintenance cost.

Optional:

- Motorised gap adjustment.
- Additional cooling rolls (depending on thickness and capacity).
- Thickness gauge system.
- Antistatic bars.

Main technical features

Models		KVA-ITF90	KVB-ITF110	KVB-ITF130
Foil width	(up to) mm	700	900	1100
Output	(up to) kg/h	700	1000	1200
Extruder *	model	EA75	EA100	EA130
Roll	(Ø) mm	400	450	500
Length	(L) mm	8200	10300	11800

* Equipped with Easy Feed® 40D or 52D.



AMUT-COMI Spa

Corso Novara, 234
27029 Vigevano (PV) - Italy

Phone +39 0381 20016
Fax +39 0381 318000
E-mail info@amutcomi.it

Follow us on 

www.amutcomi.it



AMUT COMI is part of AMUT GROUP